

Apollo Solar Electric Piston Pump™

Installation Manual and Operating Instructions

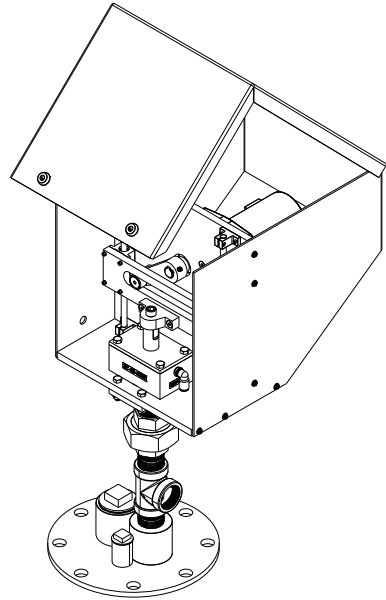
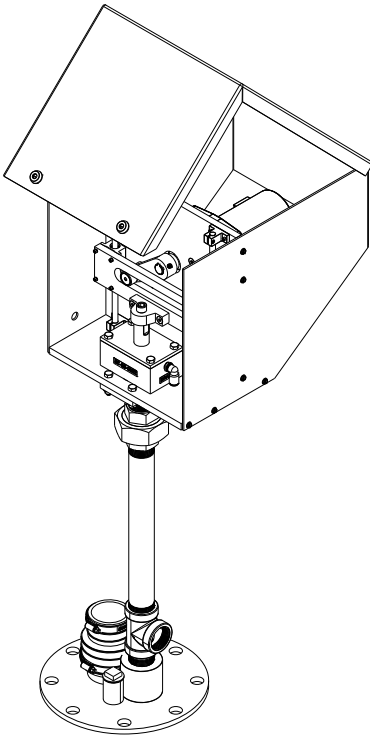

BLACKHAWK
TECHNOLOGY COMPANY

1097 Hill Avenue, Glen Ellyn IL 60137
blackhawkco.com | 630.469.4916



*Scan the QR code to view additional
technical data and documentation for
the Apollo Solar Electric Piston Pump*

Contents

Overview	2
Preinstallation	4
1. <i>Unpack</i>	4
2. <i>Gather tools</i>	4
3. <i>Measure the well depth</i>	5
4. <i>Uncoil the rod</i>	5
5. <i>Choosing the riser pipe</i>	6
6. <i>Lay out downhole pump system</i>	7
Installation	8
1. <i>Assemble the downhole components</i>	8
2. <i>Install the vanstone flange</i>	8
3. <i>Lower the pump into the well</i>	8
4. <i>Inspect the well seal</i>	8
5. <i>Lower the piston into the well</i>	9
6. <i>Measure length of the rod and cut</i>	10
7. <i>Install the top-head driver with ferrule and nut</i> ...	12
8. <i>Direct solar configuration (no batteries required)</i> ..	14
9. <i>Solar configuration with batteries</i>	15
Start Up	17
1. <i>Start up pump</i>	17
Maintenance	18
Troubleshooting Guide	20
Appendix	22

Overview

Driver Components:

- 1.) *Back Plate*
- 2.) *Guide Rails*
- 3.) *Motor*
- 4.) *Notched Yoke*
- 5.) *Splash Plate*
- 6.) *Stuffing Box*
- 7.) *Mounting Plate*

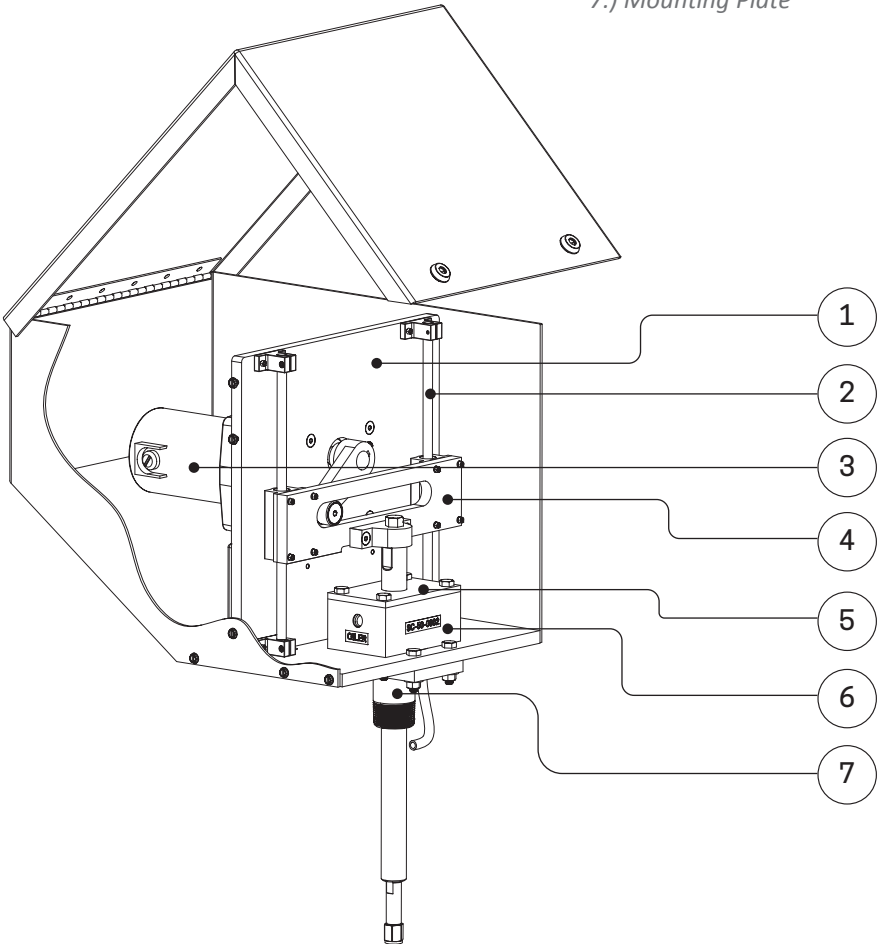

Driver Components:

8.) Hood

9.) Yoke Driver

10.) Auto Oiler (optional)

11.) Stainless Steel Drive Rod

12.) Driver Rod Connect

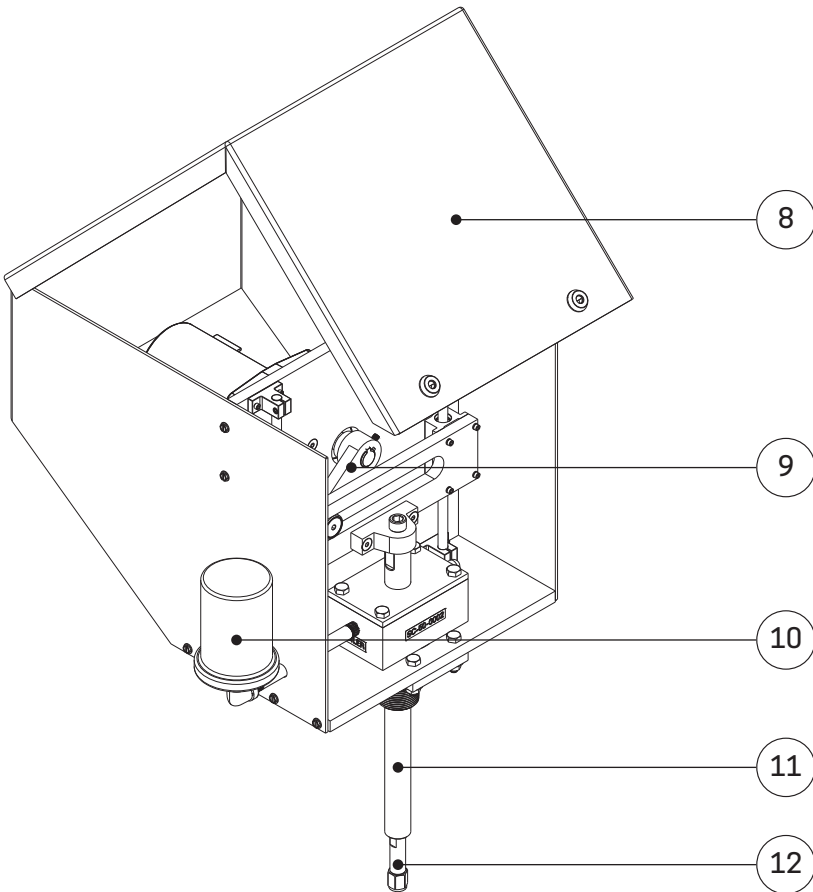

Note: See appendix for individual part numbers

Preinstallation

1. UNPACK

- a. Verify the shipment has all the necessary materials that were ordered. If any required material is missing, call (630) 469-4916.
- b. Lay out all materials for installation.

2. GATHER TOOLS

- a. Source all the tools required for installation:
 - (2) pipe wrenches
 - Crescent wrench
 - Small vice-grip pliers
 - Wire strippers
 - Voltmeter
 - Ratchet wrench with ½ inch socket
 - (4) Open-end wrenches
 - ½ inch
 - 9/16 inch
 - 5/8 inch
 - 11/16 inch
 - (2) Screwdrivers
 - Phillips
 - Flathead
 - Hacksaw
 - Measuring tape
 - Electrical tape
 - Teflon-type tape
 - Dark ink marker
- b. Source all the personal protective equipment required for installation:
 - Eye protection
 - Gloves
 - Additional PPE required by site regulations and requirements

3. MEASURE THE WELL DEPTH

- Verify the depth of the well and record it.
- You will need this information later when measuring the riser-pipe length.

4. UNCOIL ROD

- Carefully uncoil the fiberglass drive rod by walking out the coiled rod uncoiling the rod as you walk.

CAUTION: The rod is under tension, use gloves and eye protection when handling the rod.

- A ferrule and nut are already attached to the rod. They mark the rod's bottom. This is where the piston will be attached.

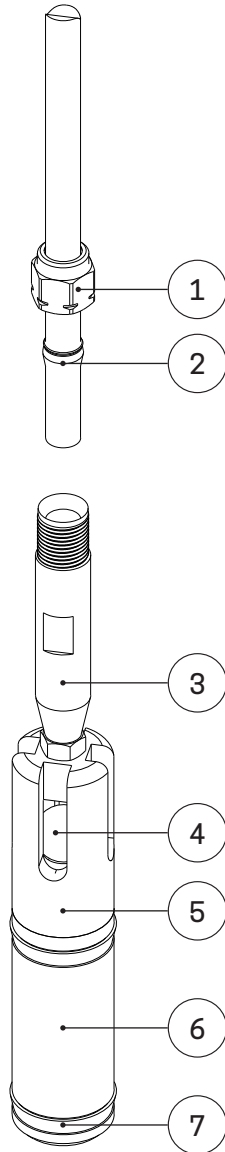

Piston Assembly Components:

- 1.) Rod Connect Nut
- 2.) Rod Connect Ferrule
- 3.) Piston Rod Connect
- 4.) Check Ball
- 5.) Piston Cage
- 6.) Piston Transition
- 7.) U-Cup Seals (x2)

5. CHOOSING THE RISER PIPE

a. The riser pipe is not supplied.

- b. The manufacturer recommends HDPE DR11 tubing for standard wells or stainless-steel pipe for elevated-temperature sites.
- c. Riser pipe diameters and lengths vary, depending on the customer's needs and the depth of the well.
- d. The riser pipe can be connected to the pump system in a number of ways depending on the type of riser pipe used and customer preference.
- e. The manufacturer can provide these connections and recommends the following:
 - Threaded NPT stainless-steel connections
 - Heat butt fuse HDPE connections
 - PPE Compression fittings for HDPE pipe (not recommended for wells longer than 100 feet in length)
 - NEVER use glued fittings

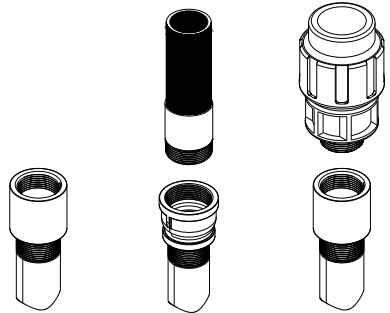
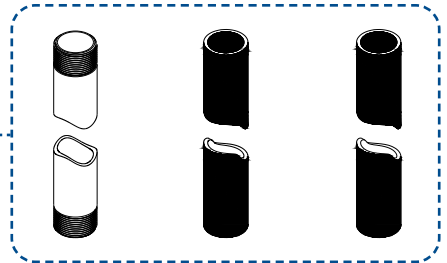
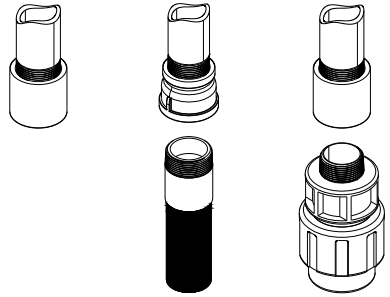

Riser Pipe Connector Types:

- 1.) NPT Threaded Pipe
- 2.) HDPE Heat Butt Fused
- 3.) PPE Compression

6. LAY OUT THE DOWNHOLE COMPONENTS OF THE PUMP SYSTEM

- a. Lay out the pump system.
- b. The well seal will be at the top and a stainless-steel pipe nipple will be threaded into the bottom. The nipple will provide rigidity and quick access to the fiberglass drive rod if it slips down the well.
- c. At the bottom of the pump system is the screen and pump barrel.
 - If the inside diameter (ID) of the riser pipe or the connections is smaller than the piston's diameter, then a pipe nipple will be added to the top of the pump barrel for maintenance purposes.
- d. The middle gap is where you will connect the riser pipe. The length of the riser pipe is dependent on the length of the well, minus the lengths of the pump barrel and the pipe nipples provided.

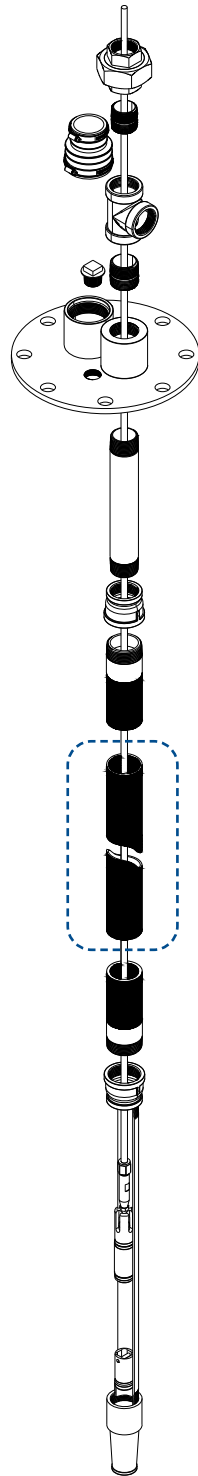

Installation

1. ASSEMBLE THE DOWNHOLE COMPONENTS

- a. Tightly secure the compression nut to the piston rod connect.
- b. Once the size of the riser pipe is determined, start making your connections.
 - If the inside diameter (ID) of the riser pipe or connections is smaller than the outside diameter (OD) of the piston, the piston must be first inserted into the pump barrel and drive rod inserted through riser pipe, connections and tubing prior to assembly of the downhole.
 - Use plumber's tape on all threaded connections of the riser pipe to ensure the connections do not leak.

2. INSTALL THE VANSTONE FLANGE

- a. Secure the vanstone flange to the top of the well casing.
- b. Place the rubber gasket on top of the vanstone flange.

3. LOWER THE DOWNHOLE COMPONENTS INTO THE WELL

- a. Carefully slide the pump barrel into the well, screen first. Avoid 90 degree bends to the riser pipe.
- b. Line the well seal up with the vanstone flange.
- c. Bolt the well seal to the vanstone flange.
See diagram on next page for reference.

4. INSPECT THE WELL SEAL

- a. Well seals are sized and designed to fit the customer's needs.
- b. There are typically 3 ports on each well seal. One port is the actuator mount. At this port you will install the close nipple and discharge tee.
 - A pipe union can be installed above the tee for ease of future maintenance.
- c. The other two ports can be used for monitoring and drainage. The larger port also can accommodate a gas collection system. *Refer to Appendix, Page 31: "ADDITIONAL OPTIONS: Gas Extraction Well Seal Configuration."*

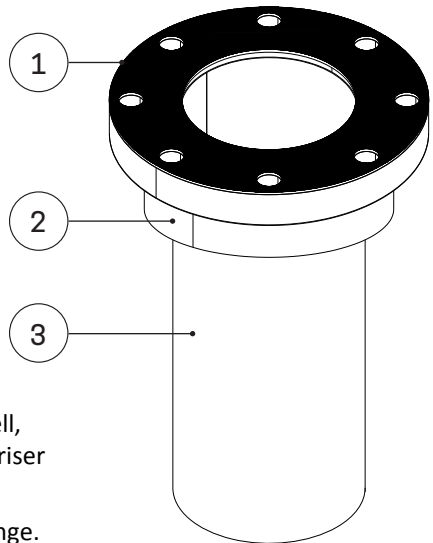

Flange Components:

- 1.) Rubber Gasket
- 2.) Vanstone Flange
- 3.) Well Casing

5. LOWER THE PISTON INTO THE WELL

- a. Lower the piston and fiberglass drive rod into the well. Keep lowering the rod until you feel the piston rest at the bottom of the pump barrel.
 - Refer to step 1b if the ID of the riser pipe or connections is smaller than the OD of the piston
- b. Hand pump the drive rod to ensure the piston is pumping liquid. You will start to feel resistance when there is sufficient liquid entering the riser pipe.

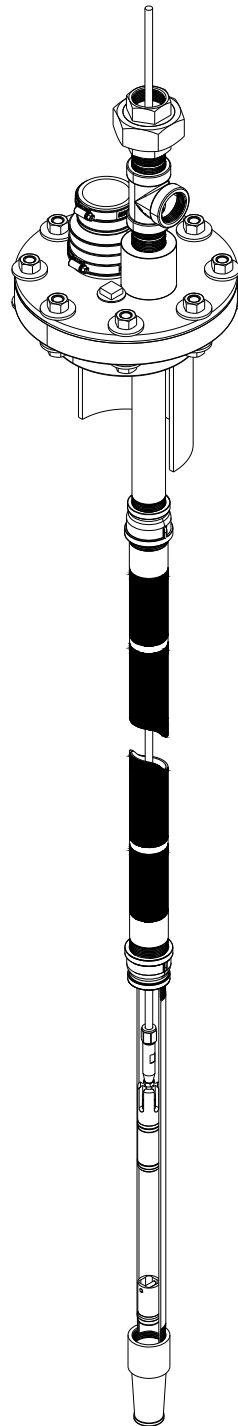

6. MEASURE LENGTH OF THE ROD AND CUT

See Rod Cutting Diagram on next page for reference.

- a. Make sure the piston is resting at the bottom of the pump barrel. *See Step 1.*
- b. Mark the rod at the top of the tee or pipe union with a marker. *See Step 2.*
- c. Pull 3 to 4 feet of rod from the well. *See Step 3.*
- d. Wrap tape around the fiberglass drive rod where it meets the tee or pipe union. Clamp vice grips to the tape. **NOTE: This secures the drive rod at the surface and prevents rod from dropping into the well.** *See Step 4.*
- e. From the first mark, measure exactly 20 inches down the fiber glass drive rod and make a second mark. *See Step 4.*
- f. Using the hacksaw, carefully cut the fiberglass drive rod at the second mark. Cut on both sides to ensure the rod does not split. *See Step 4.*
- g. When cut correctly, there will be an 8 inch gap between the top of the piston and the top of the pump barrel, when the piston is in the “up” position of the stroke.

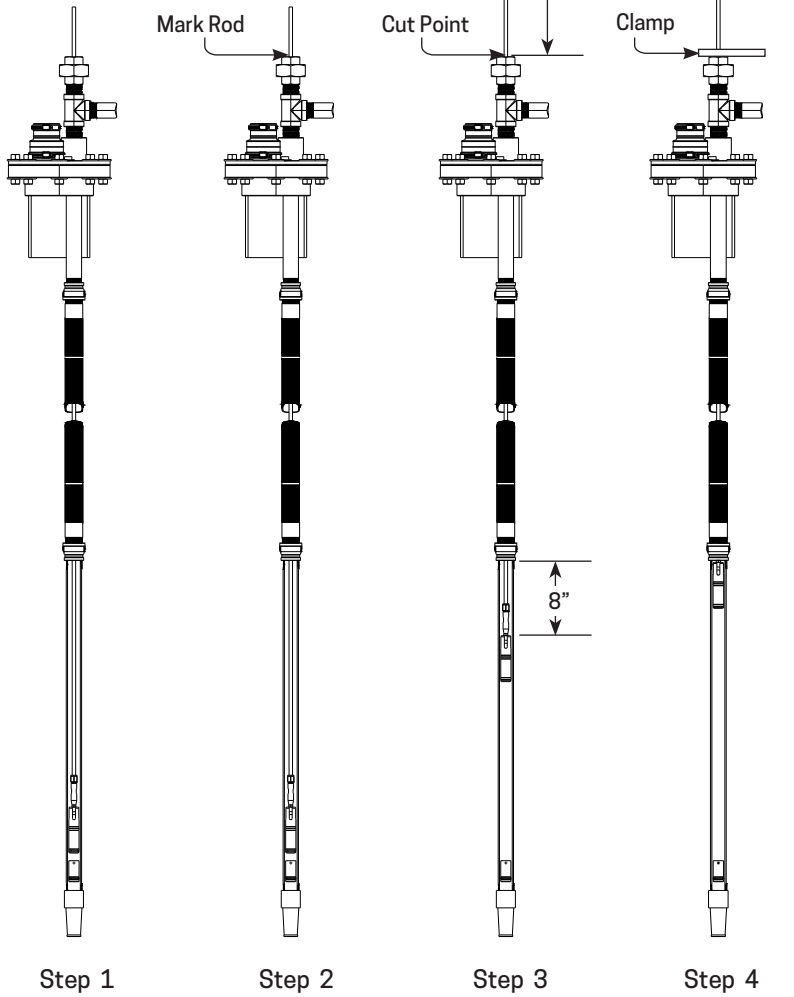

Step 1

Step 2

Step 3

Step 4

Rod Cutting Diagram

7. INSTALL THE TOP-HEAD DRIVER WITH FERRULE AND NUT

See figures on next page for reference.

- a. Retrieve the ferrule and nut from the actuator. They will be loosely fastened to the actuator's rod to motor connect. *See Step 1.*
- b. At the cut end of the fiberglass drive rod, lower the compression nut, facing outward, onto the rod. Then lower the ferrule onto the drive rod. *See Step 1.*
- c. Retrieve the actuator and slide the drive rod into motor connect with the ferrule and nut below it. *See Step 2.*
- d. Tighten the nut and ferrule to the rod to motor connect. **Fasten tightly.** The ferrule needs to dig itself into the fiberglass drive rod. When done correctly, the ferrule will have mushroomed out and there will be a faint white line where the ferrule has dug into the rod. *See Step 2.*
- e. Remove vice grips and tape from the fiberglass drive rod and lower the actuator into position over the tee or union.
- f. Attach the actuator to the well seal at the tee or union. Secure tightly to prevent leaks.
- g. Attach auto oiler to the actuator, if purchased.
- h. Attach discharge piping to the discharge tee on the well seal.

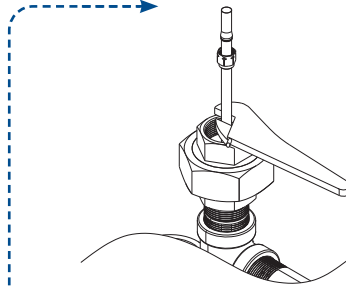
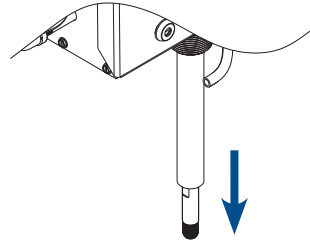
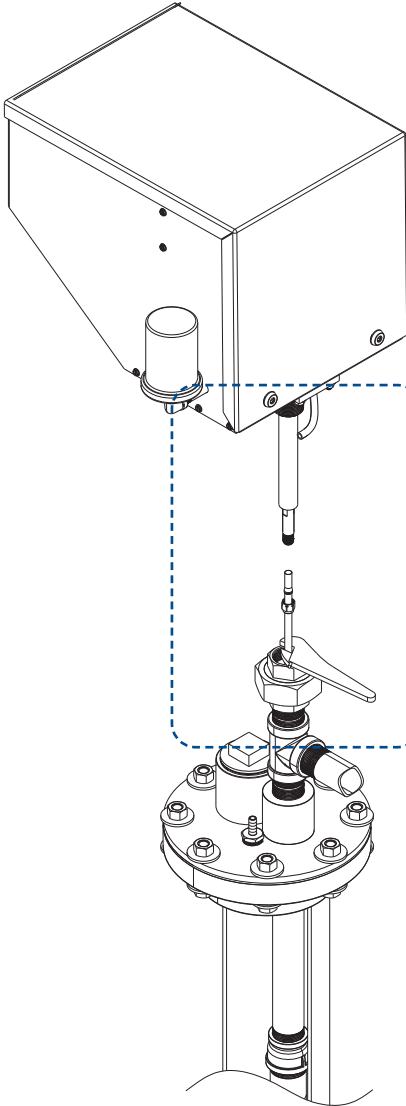

Step 1

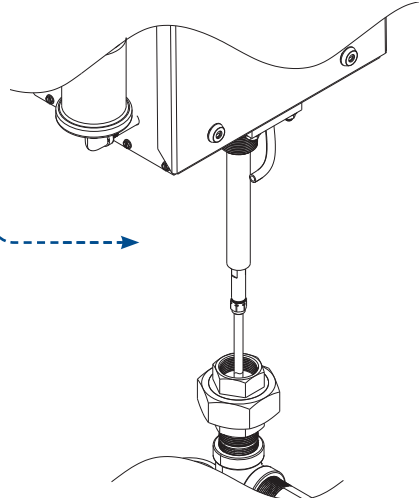

Step 2

8. DIRECT SOLAR CONFIGURATION (NO BATTERIES REQUIRED)

- a. Blackhawk's Direct Solar Power Setup includes the following items:
 - 300-380 Watt, 24 Volt Solar Panel
 - Solar Controller
 - 30' Cable
 - Side Pole Mount with 55' panel supports
- b. Anchor solar panel mounting pole securely to a stable structure.
 - Pole should be 3-4.5" in diameter to secure the side pole mount.
- c. Assemble panel supports as instructed by the solar panel support instructions included in the shipment.
- d. Mount solar panel to the pole.
- e. For most cases, point the solar panel to true south for best absorption.
 - Solar panel direction may change depending on the longitudinal and latitudinal location. Consult with Blackhawk or local solar panel supplier for specific directional information.
- f. Retrieve the 30' cable.
 - The cable has male and female panel connections already wired on each end.
- g. Cut the 30' cable in half.
- h. Consult the wiring diagram located in the Appendix, Page 28: "WIRING DIAGRAM: Solar - Direct" for more detailed instructions.**
- i. Identify which connections correspond to the + and - voltage based on the connection leads coming off the solar panel.
- j. Wire the cut end of the cable to the solar controller in the + and - ports marked "PV" on the solar controller.
- k. Wire the motor leads to the solar controller in the + and - ports marked "Load" on the solar controller.
 - It is recommended to install a breaker between the positive motor lead and the solar controller to prevent damage to the motor if it encounters a clogged intake or dead head conditions during actuation. The amperage of the breaker depends on the motor type, consult Blackhawk for the correct breaker.
- l. Proceed to the Startup section on page 17.

9. SOLAR CONFIGURATION WITH BATTERIES

- a. Blackhawk's Battery Solar Power Setup includes the following items:
 - 300-380 Watt, 24 Volt Solar Panel
 - Solar Controller
 - 30' Cable
 - Side Pole Mount with 55' panel supports
 - Breaker Enclosure
 - Relay Switch
 - 20-30 Amp Breaker
 - **BATTERIES AND BATTERY ENCLOSURE NOT SUPPLIED**
- b. Anchor solar panel mounting pole securely to a stable structure.
 - Pole should be 3-4.5" in diameter to secure the side pole mount.
- c. Assemble panel supports as instructed by the solar panel support instructions included in the shipment.
- d. Mount solar panel to the pole.
- e. For most cases, point the solar panel to true south for best absorption.
 - Solar panel direction may change depending on the longitudinal and latitudinal location. Consult with Blackhawk or local solar panel supplier for specific directional information.
- f. Retrieve the 30' cable.
 - The cable has male and female panel connections already wired on each end.
- g. Cut the 30' cable in half.
- h. **Consult the wiring diagram located in the Appendix, Page 29: "WIRING DIAGRAM: Solar - With Batteries" for more detailed instructions.**
- i. Identify which connections correspond to the + and - voltage based on the connection leads coming off the solar panel.
- j. Wire the cut end of the cable to the solar controller in the + and - ports marked "PV" on the solar controller.
- k. Wire batteries in series.
 - The battery type and the number of batteries is dependent on the client's needs and preference. Consult with Blackhawk or a local solar panel supplier for more information.

9. SOLAR CONFIGURATION WITH BATTERIES, CONTINUED

- l. Wire battery leads to the solar controller in the + and - ports marked “Batt” on the solar controller.
- m. Wire the cut end of the cable to the solar controller in the + and - ports marked “PV” on the solar controller.
- n. Wire the motor leads to the solar controller in the + and - ports marked “Load” on the solar controller.
 - It is recommended to install a breaker between the positive motor lead and the solar controller to prevent damage to the motor if it encounters a clogged intake or dead head conditions during actuation. The amperage of the breaker depends on the motor type, consult Blackhawk for the correct breaker.
- o. Proceed to the Startup section on page 17.

Start Up

1. START UP PUMP

- a. Confirm there is nothing obstructing the moving parts within the actuator housing.
- b. Confirm the switch on the back of the actuator is in the "Off" position.
- c. Connect the discharge line to the discharge tee at the well seal.
- d. Connect panel cables to their corresponding connector on the solar panel.
- e. Flip the switch on the actuator to the "On" position.
- f. Apollo Solar electric piston pump should now be operational.

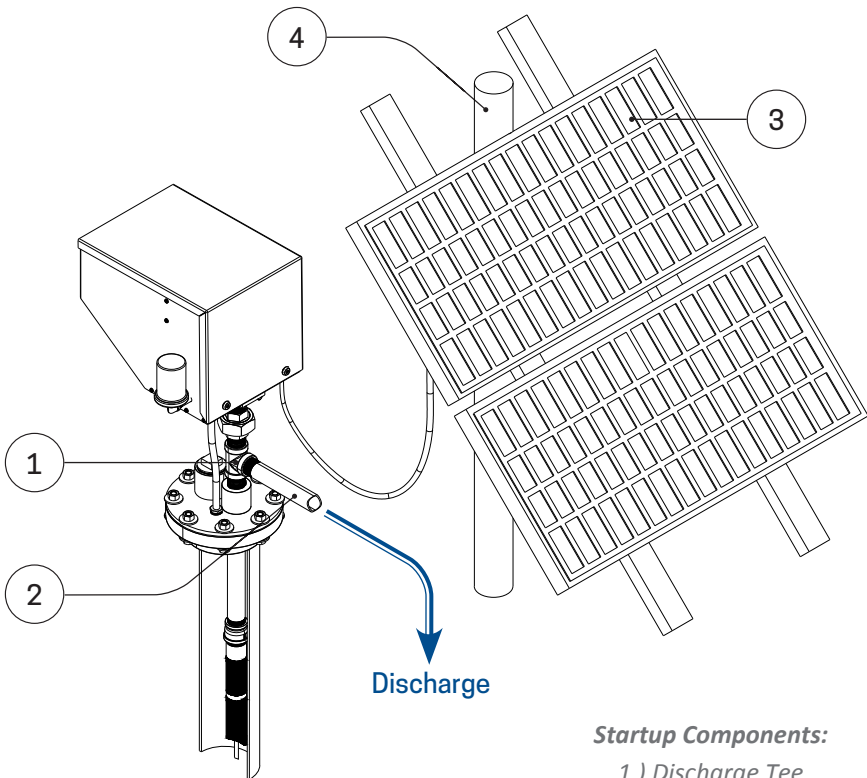

Startup Components:

- 1.) Discharge Tee
- 2.) Discharge Line
- 3.) Solar Panel
- 4.) Mounting Pole

Maintenance

PERIODIC CHECKS

- Check pump back pressure at the discharge tee.
 - Refer to Appendix, Page 35: “FIGURE 1: FLOW vs DEPTH Apollo Solar 101 and 102”
- Check liquid discharge rate at the discharge tee.
 - Refer to Appendix, Page 35: “FIGURE 1: FLOW vs DEPTH Apollo Solar 101 and 102”
- Check for tripped breakers.
 - Refer to Troubleshooting, Page 20, Section 1.a: “Breakers Tripped”
- Check for any grinding noises coming from the actuator bearings.
- Check stuffing box drain port for leaks.
 - See next section below.

REPLACING STUFFING BOX SEALS

- Refer to Apollo Stuffing Box Replacement Guide (external document) & various stuffing box / cartridge configurations in Appendix, Pages 24-26
- Stuffing box seals will wear over time.
 - Seal life depends on discharge pressure, stroke speed, grit and temperature of liquid.
 - Once the seals wear, the stuffing box will begin to leak liquid from the drain port. [Replace stuffing box seals at this time.](#)

REPLACING PISTON SEALS

- Piston seals will wear over time.
 - Once the seals wear, there will be a loss of liquid discharge measured at the discharge tee. [Replace piston seals at this time.](#)

LUBRICATION

- Actuator Linear Bearings
 - Apply 3 drops of 10-weight oil or 3-in-1 oil, once a month.
- Stuffing Box - Grease Zerk Fitting
 - One hand pump of synthetic grease, once a month.
 - **DO NOT** use auto grease gun or over grease, this will cause the stuffing box seals to fail.
- Stuffing Box - Auto Oiler System
 - Use 6-month auto oiler fitting.
 - Replace oiler cartridge and battery when oiler bladder runs dry.

CAUTION AND RECOMMENDATIONS

- **DO NOT** operate pump with the discharge valve closed or discharge pipe clogged, this will result in stuffing box seal failure.
- **DO NOT** scratch the actuator's drive motor stainless-steel piston rod, this will result in premature stuffing box seal wear.
- **DO NOT** use CLR or comparable chemicals on the aluminum components of the actuator drive motor.
- Recommend simple green and/or paint thinner for cleaning.
- Recommend back pressure not exceed 50 PSI, higher back pressure at the discharge tee will result in faster stuffing box seal wear.
- Recommend use of synthetic grease, synthetic spray lubricant, or 3-in-1 oil for lubrication. WD-40 is not recommended.

Troubleshooting Guide

1. DRIVER NOT RECIPROCATING OR STUTTERING WHILE IN USE

a. Breakers Tripped

- This is an indication that there is excessive backpressure at the discharge tee or there is a clogged intake down well, resulting in possible amperage overload of the motor beyond specified limit for the unit.
- Check voltage of the solar panel and motor at the solar controller using a voltmeter.
 - If using the Solar Configuration With Batteries, check the voltage of the batteries using the voltmeter or using the Bluetooth application. The controller will not turn on the load until the voltage of the batteries reaches a certain point programmed into the controller. This protects the batteries from degradation.

b. Excessive Back Pressure In Discharge Line

- Verify that the discharge valve is in the open position.
- Relieve pressure in the discharge line.
- Check for and remove any obstructions in the discharge pipe.
- Check maximum Total Dynamic Head (TDH) for the appropriate pumping setup.
 - Refer to Appendix, Page 35: "FIGURE 1: FLOW vs DEPTH Apollo Solar 101 and 102"

2. DRIVER RECIPROCATING BUT NOT PUMPING LIQUID

a. Liquid Level In Riser Pipe Insufficient For Discharge

- Liquid level in the riser pipe will take time until it is filled to the level of the discharge tee
- Find the time it takes the liquid to reach the tee
 - Refer to Appendix, Page 35: "FIGURE 2: Liquid Fill Time Per Pump and Riser Pipe Type"

b. Leak In Riser Pipe And/Or Connections

- If liquid is not filled up to the discharge tee, then it is an indication of a leaking riser pipe
- Remove pump system from the well
- Check riser pipe and connections for leaks
- Tighten all connections

c. Fiberglass Drive Rod Disconnected

- Remove the pumping system from the well
- Verify that the fiberglass drive rod is connected to the driver and to the piston
 - If fiberglass drive rod is separated at the compression fitting, a replacement drive rod ferrule will be required (ferrules cannot be re-crimped)

d. Foot Valve And/Or Piston Check Ball Obstructed

- Remove pump system from the well
- Clear debris from the pump barrel, foot valve, piston, and riser pipe
 - Debris or obstructions can cause uneven contact between the check ball and the stainless-steel seat, preventing a proper seal in either the piston or the foot valve

e. Plugged Bottom Intake

- Perform the glove test (see below) to determine if intake is plugged
- If intake is plugged because it was placed in mud or silt, raise the pump system so that the intake is clear of the obstruction

d. The Liquid Level Has Dropped Below The Intake

- Measure the liquid level of the well
- Extend the the pump system to reach the new liquid level
 - Refer to Appendix, Page 33: "ADDITIONAL OPTIONS: Vertical Stinger Suction Extension"

THE GLOVE TEST

- Remove discharge line from tee
- Firmly wrap a rubber glove around the discharge tee, sealing it with your hand or a rubber band
- If the glove slowly inflates during actuation, then the pump is raising liquid to the surface and displacing the air in the riser pipe
- If the glove breaths in and out then there is liquid in the riser pipe but the pump barrel is clogged
- If the glove does not inflate then refer to issues b-d in the previous troubleshooting section, Section 2 (Leak In Riser Pipe And/Or Connections, Fiberglass Drive Rod Disconnected, Foot Valve And/Or Piston Check Ball Obstructed)

Appendix

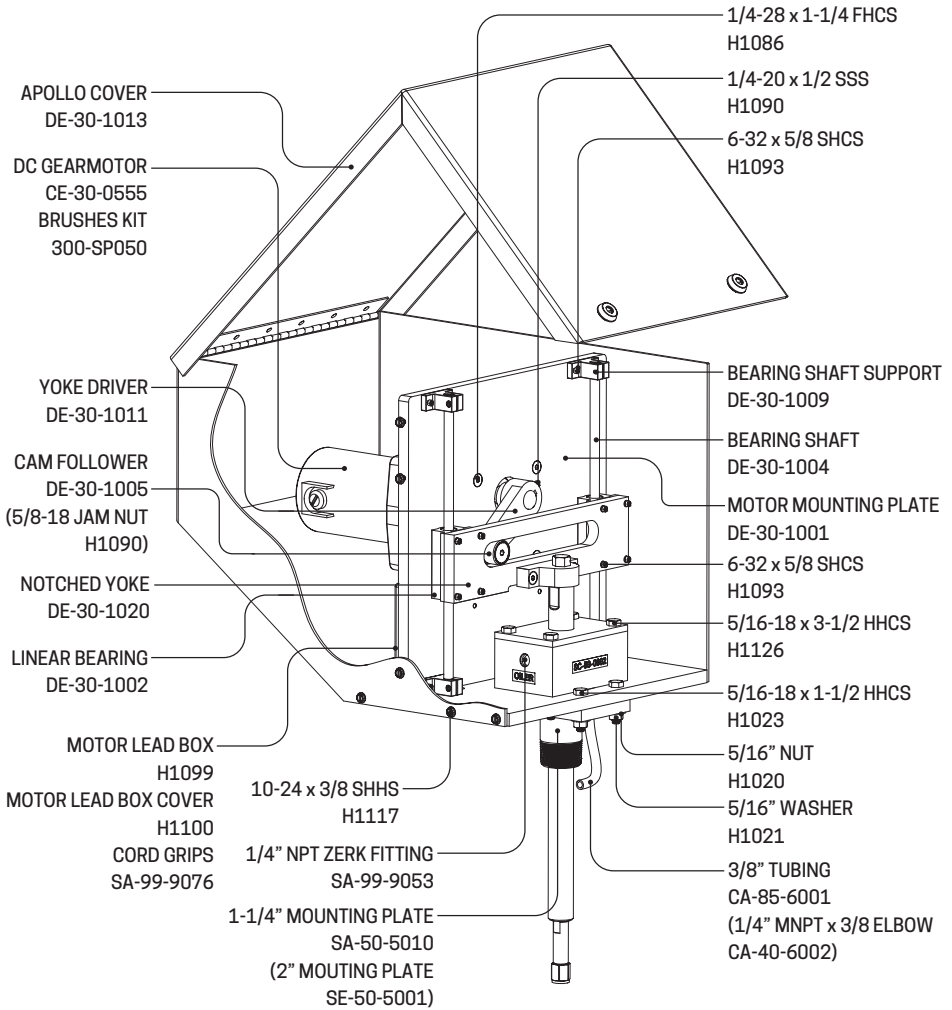

PART NUMBERS: Apollo Solar Drive Motor Assembly, Part 1

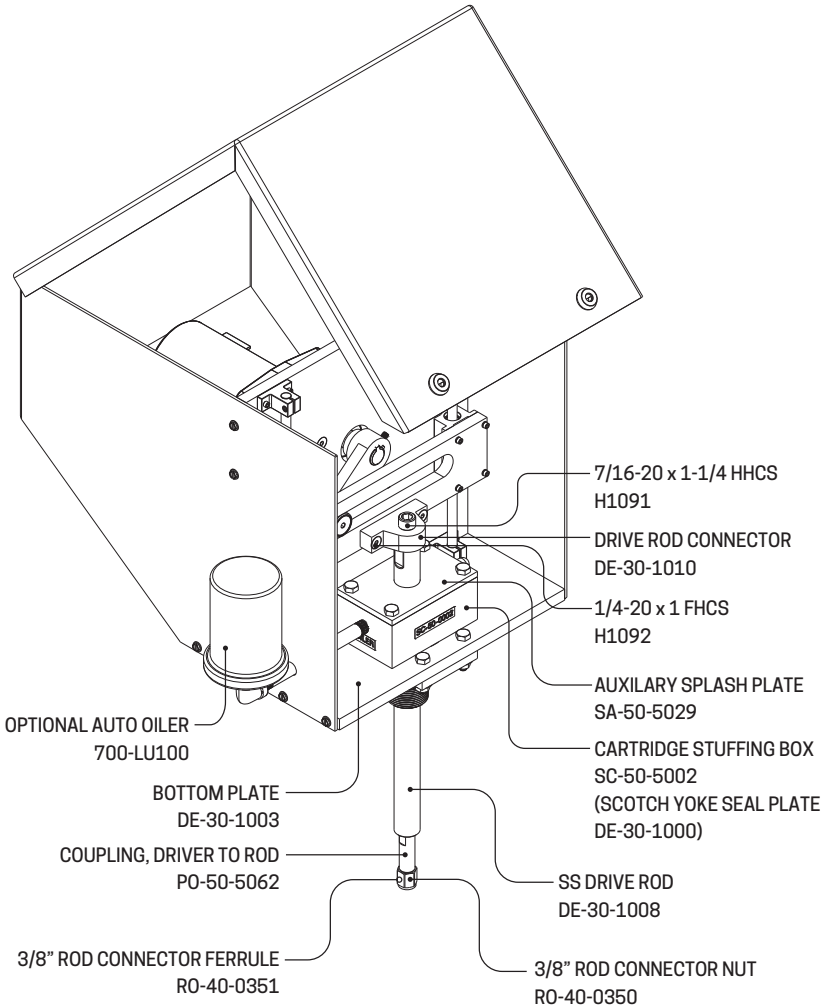

PART NUMBERS: Apollo Solar Drive Motor Assembly, Part 2

Appendix

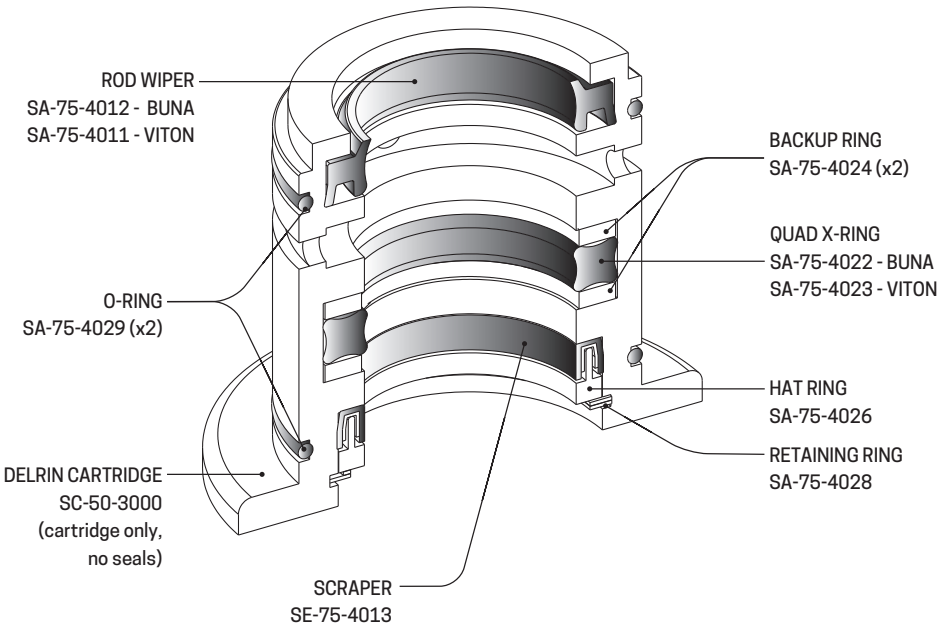
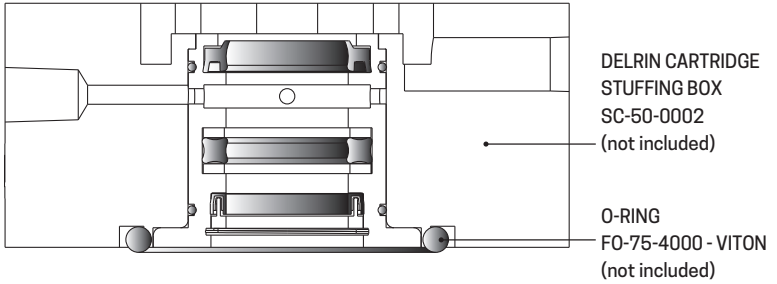

Seal Kits

BUNA SEAL KIT	800-SCHRB
CARTRIDGE WITH BUNA SEALS	810-SCHRB
VITON SEAL KIT	800-SCHRV
CARTRIDGE WITH VITON SEALS	810-SCHRV

CARTRIDGE SEAL KITS: 1" Rod Hat-Ring Cartridge Assembly

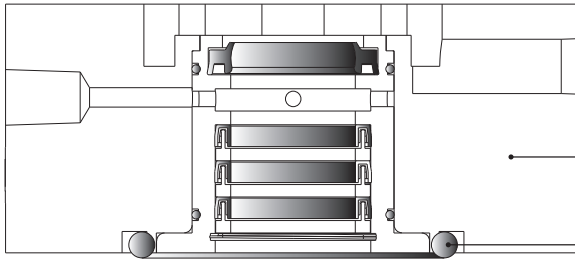

DELTRIN CARTRIDGE
STUFFING BOX
SC-50-0002
(not included)

O-RING
FO-75-4000 - VITON
(not included)

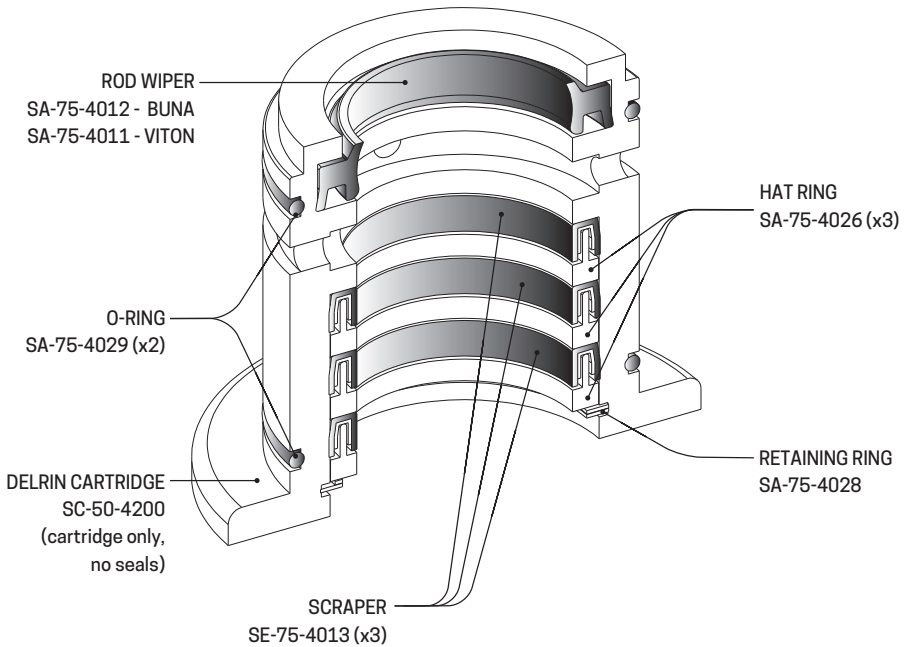

ROD WIPER
SA-75-4012 - BUNA
SA-75-4011 - VITON

O-RING
SA-75-4029 (x2)

DELTRIN CARTRIDGE
SC-50-4200
(cartridge only,
no seals)

SCRAPER
SE-75-4013 (x3)

HAT RING
SA-75-4026 (x3)

RETAINING RING
SA-75-4028

Seal Kits

BUNA SEAL KIT	800-SCHRSTB3
CARTRIDGE WITH BUNA SEALS	813-SCHRSTB3
VITON SEAL KIT	800-SCHRSTV3
CARTRIDGE WITH VITON SEALS	813-SCHRSTV3

CARTRIDGE SEAL KITS: 1" Rod V-Stack Cartridge Assembly

Appendix

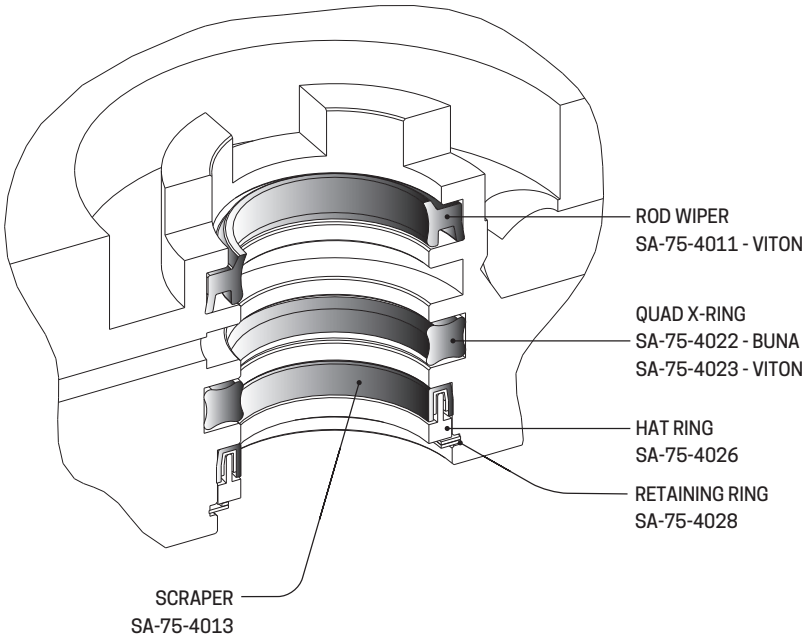
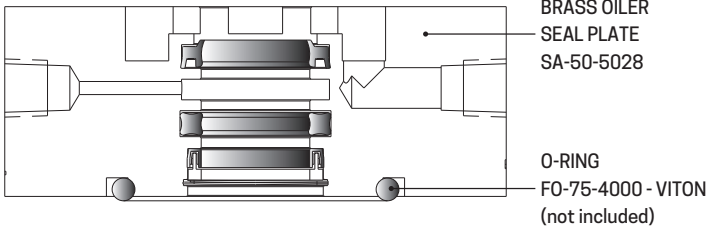

Seal Kits

BUNA SEAL KIT	800-SOLB
VITON SEAL KIT	800-SOLV

ADDITIONAL OPTIONS: 1" Brass Oiler Seal Plate Assembly

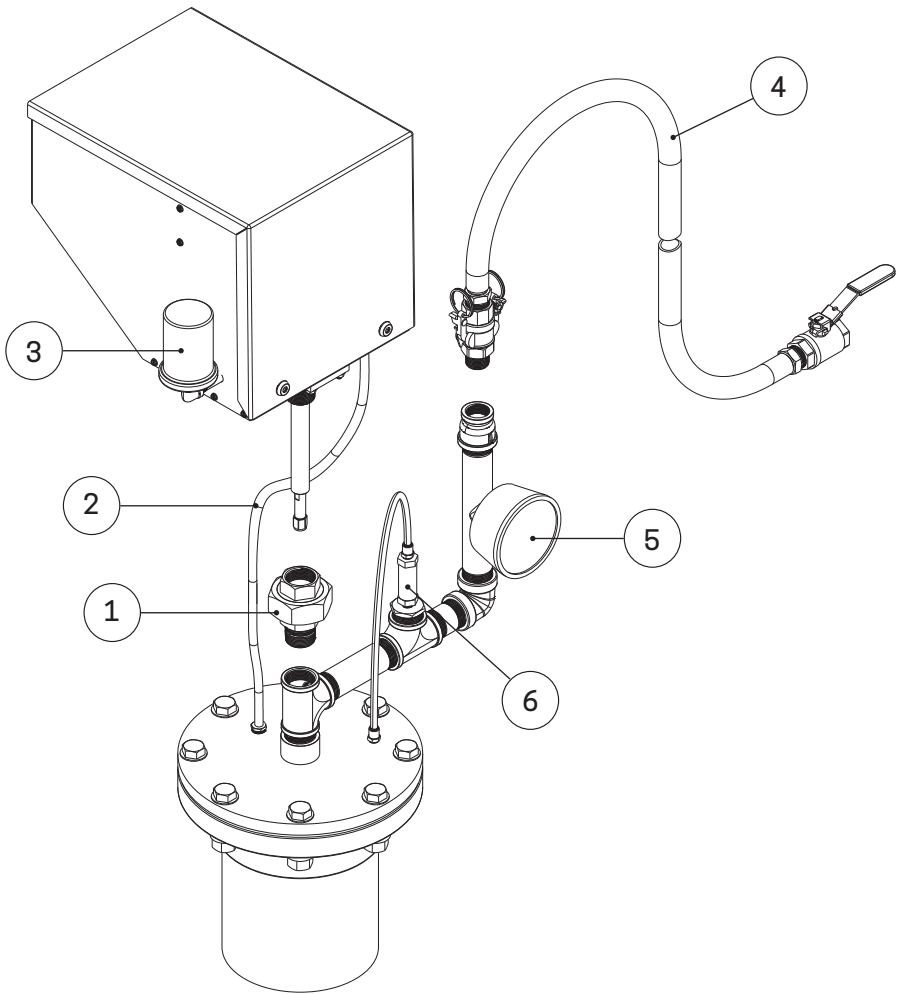

Optional Components

1	700-UN001	1-1/4" PIPE UNION ASSEMBLY
2	700-HD101	1/4" NPT DRAIN KIT
3	NS-PL001	AUTO LUBRICATOR
4	700-AS140	DISCHARGE KIT
5	** VARIES **	FLOW METER
6	NS-FP001	PRESSURE RELIEF VALVE

ADDITIONAL OPTIONS: Apollo Accessories Guide

Appendix

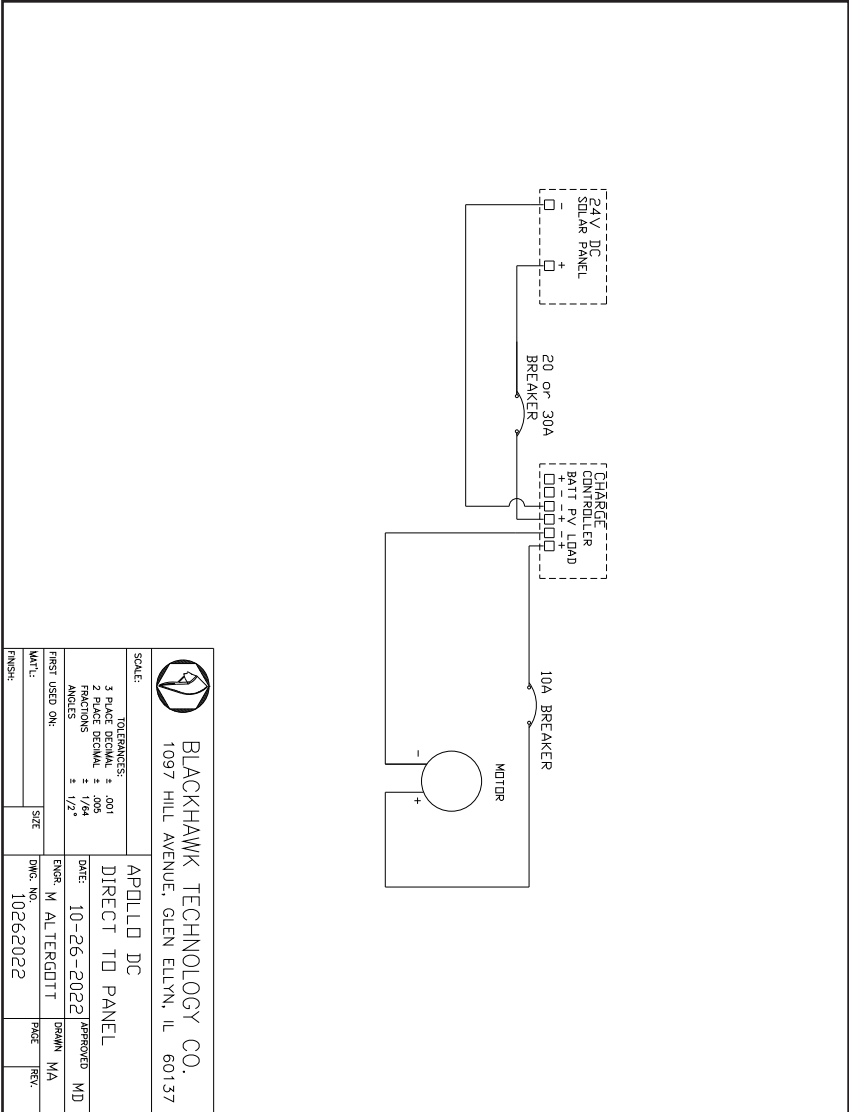

BLACKHAWK TECHNOLOGY CO.
 1097 HILL AVENUE, GLEN ELLYN, IL 60137

SCALE:		TOLERANCES:	
3 PLACE DECIMAL	± .001	2 PLACE DECIMAL	± .005
4 PLACE DECIMAL	± .0005	1 PLACE DECIMAL	± .050
ANGLES	± 1/2°		
FIRST USED ON:		SIZE	
MATERIAL:		DESCR:	APOLLO DC DIRECT TO PANEL
FINISH:		DATE:	10-26-2022
		ENGR:	M ALTERGOTT
		DWG. NO.:	10262022
		DESIGN:	MA
		DATE:	REV.

WIRING DIAGRAM: Solar - Direct

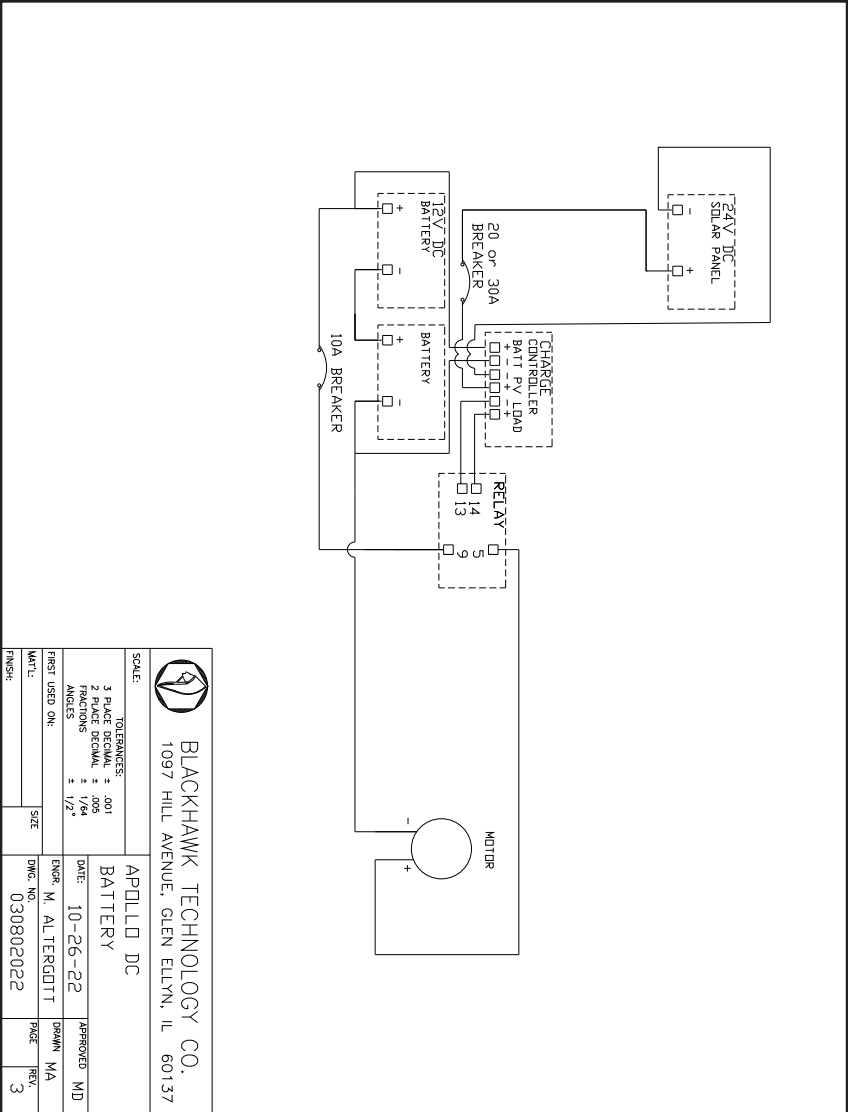

WIRING DIAGRAM: Solar - With Batteries

Appendix

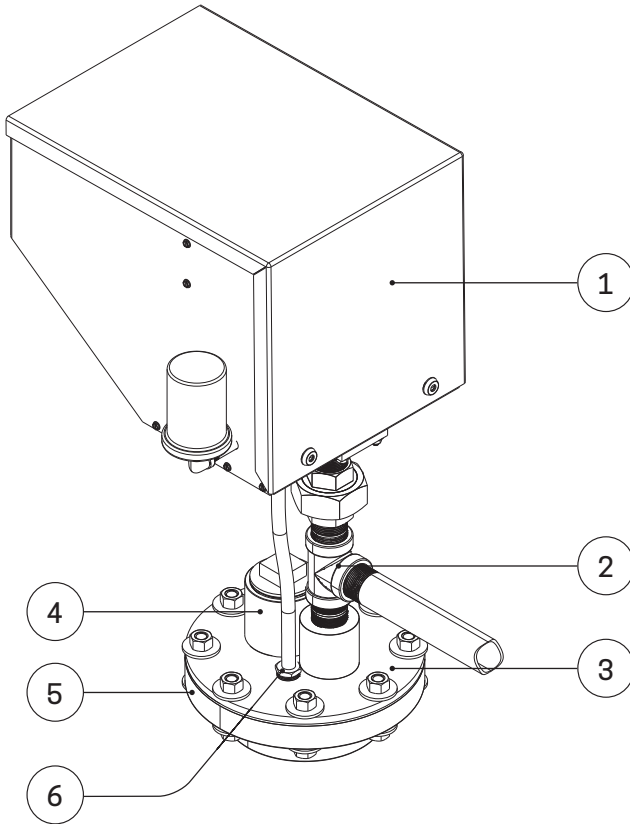

Labeled Components

1	APOLLO SOLAR ELECTRIC DRIVE MOTOR ASSEMBLY
2	DISCHARGE TEE
3	STEEL FLANGED WELL SEAL
4	2" NPT THREADED PORT W/CAP
5	VANSTONE FLANGE
6	AUXILLIARY ACCESS PORT (DRAIN FUNCTION SHOWN)

ADDITIONAL OPTIONS: *Standard Well Seal Configuration*

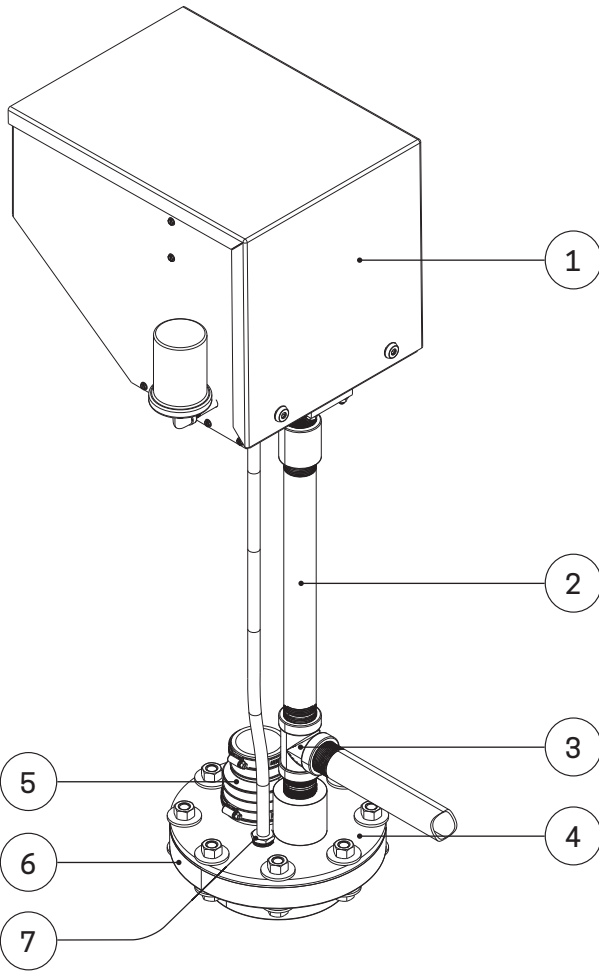

Labeled Components

1	APOLLO SOLAR ELECTRIC DRIVE MOTOR ASSEMBLY
2	EXTENDED STEEL NIPPLE
3	DISCHARGE TEE
4	STEEL FLANGED WELL SEAL
5	FERNCO FITTING (GAS EXTRACTION PORT)
6	VANSTONE FLANGE
7	AUXILLIARY ACCESS PORT (DRAIN FUNCTION SHOWN)

ADDITIONAL OPTIONS: Gas Extraction Well Seal Configuration

Appendix

NOTE:

Blackhawk's unique design allows all its pumps to pump liquid from vertical to near horizontal wells. Skid runners are recommended for wells nearing horizontal orientation. The skid runners ensure that the pump's intake does not rest directly on the well casing.

See note below for selecting correct skid runners based on downhole size.

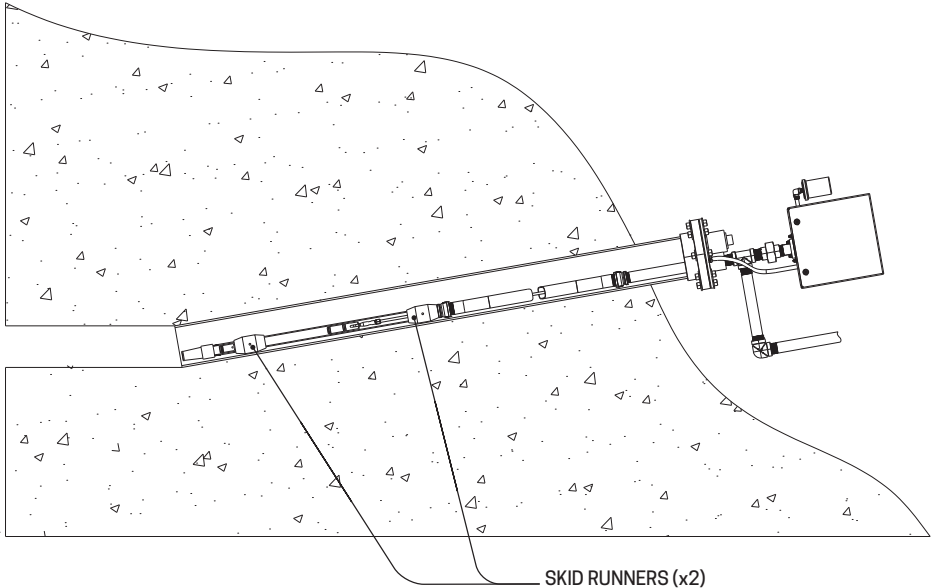

SKID RUNNERS (x2)

101 Downhole: FO-50-5011

102 Downhole: FO-50-5008

103 Downhole: FO-50-5009

ADDITIONAL OPTIONS: *Sideslope Downhole Capability*

NOTE:

The vertical stinger suction extension is a quick way to add 10 extra feet of suction depth to an already assembled pump system.

INSTRUCTIONS:

- Pull pump system from the well in its entirety.
- Remove intake screen from the bottom of the pump barrel.
- Attach coupling and piping to the bottom of the pump barrel to reach the desired new depth (10 feet MAX).
- Reinstall the pump into the well.

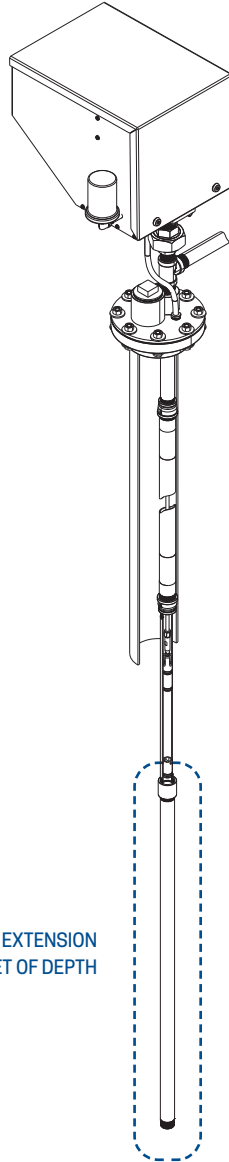

STINGER EXTENSION
10 FEET OF DEPTH

ADDITIONAL OPTIONS: Vertical Stinger Suction Extension

Appendix

NOTE:

The sinker rod is an optional downhole drive rod component used to address rod-fall issues that may potentially arise under certain conditions:

- Pumping viscous fluids
- High stroke speeds
- Well depth over 100 feet

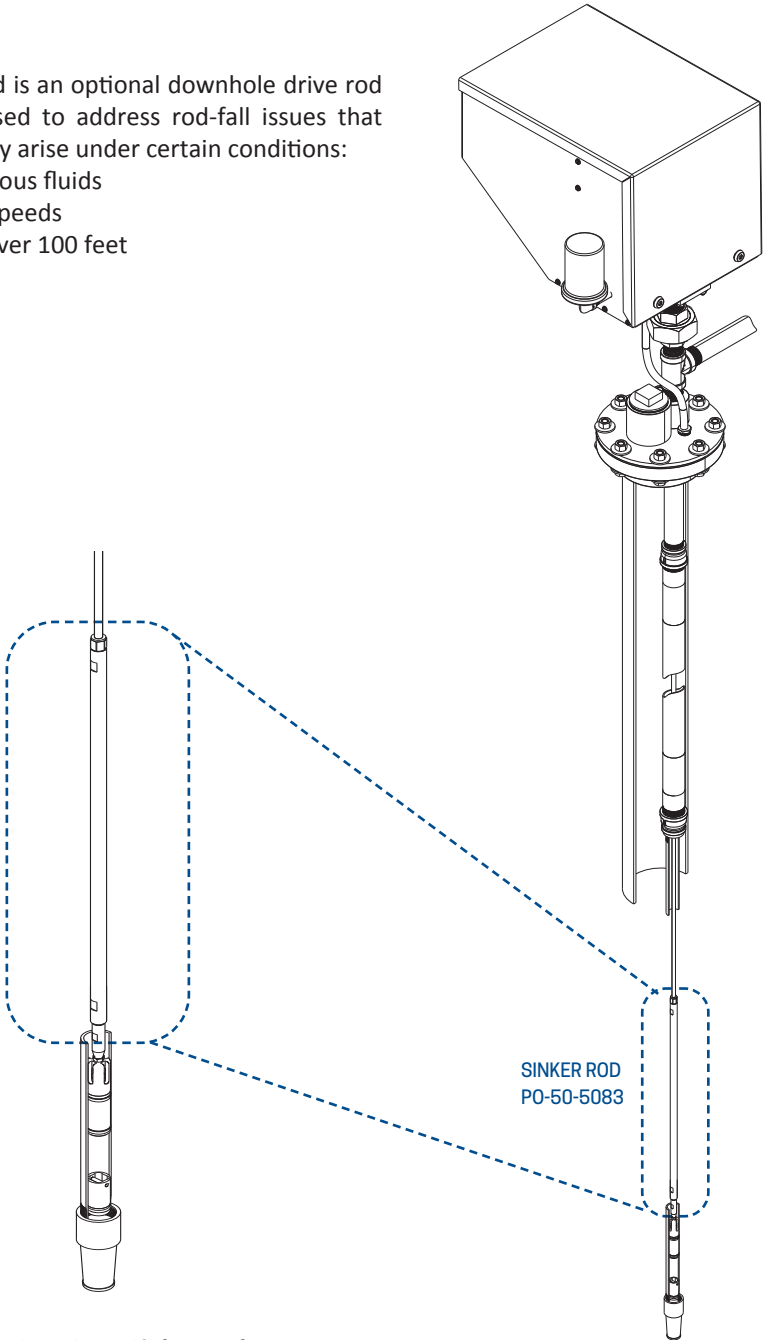

ADDITIONAL OPTIONS: *Sinker Rod*

FLOW vs. DEPTH Apollo Solar 101 and 102

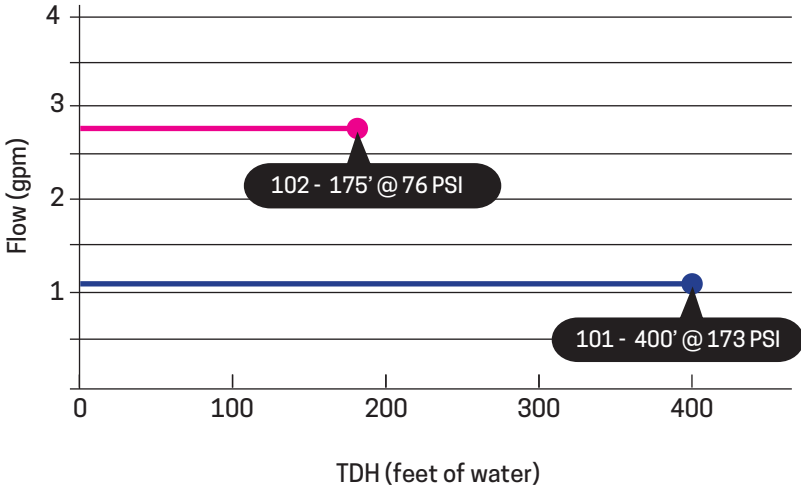

FIGURE 1: Flow Rate vs Depth Apollo Solar 101 and 102

Liquid Fill Time Per Pump & Riser Pipe Types (Based on 100' well depth)						
Pump Barrel Size	Actuator Type	gpm	Riser Pipe Type and Size			
			HDPE DR 11 Pipe		Schedule 40 Pipe	
			1-1/2"	2"	1-1/4"	2"
101	Apollo	1.10	8:12	13:06	6:32	15:19
	Pneumatic	2.00	4:30	7:12	3:35	8:25
	Anchor	1.35	6:41	10:40	5:19	12:29
102	Apollo	2.70	3:20	5:20	2:39	6:14
	Pneumatic	5.00	1:48	2:53	1:26	3:22
	Anchor	3.27	2:45	4:24	2:12	5:09

FIGURE 2: Liquid Fill Time Per Pump and Riser Pipe Type

Appendix

MAXIMUM OPERATING DEPTH	400 FEET (122 METERS)
MAXIMUM FLOW RATE - PER MIN	UP TO 1.1 US GPM (4.16 LPM)
MAXIMUM FLOW RATE - PER DAY	UP TO 1,584 US GPD (5,996 LPD)
MOTOR	3/8 HP, 14 AMPS
POWER SUPPLY	24VOLT DC, 385 WATTS PANEL, 9.6 AMP
MAXIMUM LIFT	400 FEET (122 METERS) OF WATER AT 173 PSI
DISCHARGE PER STROKE	0.026 GALLONS (0.098 LITERS)
TEMPERATURE RANGE	UP TO 200° F / 93° C

FIGURE 3: Performance Data - 101 Downhole

MAXIMUM EXTERNAL DIAMETER	1.9 INCHES (5.08 CENTIMETERS)
CONNECTION TO RISER PIPE	1-1/4 INCHES (3.18 CENTIMETERS)
CONNECTION TUBING	3/4 INCHES (1.9 CENTIMETERS) OR GREATER
RECOMMENDED INTERNAL BORE-HOLE DIAMETER	2 - 3 INCHES (5.08 - 7.62 CM) OR GREATER
DISCHARGE SIZE	2 INCHES OR 1-1/4 INCHES NPT
INSTALLATION	ANY ANGLE FROM VERTICAL TO HORIZONTAL
DRIVER WEIGHT	60 POUNDS (27.22 KILOGRAMS)
DRIVER ROD WEIGHT	12 LBS PER 100 FT (3.7 KG PER 100 M)
FOOT VALVE ASSEMBLY WEIGHT	17 POUNDS (7.71 KILOGRAMS)
MINIMUM WELL CASING SIZE	2 INCHES (5.08 CENTIMETERS)
FOOT VALVE ASSEMBLY WEIGHT	20 POUNDS (9.1 KILOGRAMS)

FIGURE 4: Technical Data - 101 Downhole

MAXIMUM OPERATING DEPTH	175 FEET (53 METERS)
MAXIMUM FLOW RATE - PER MIN	UP TO 2.7 US GPM (10.2 LPM)
MAXIMUM FLOW RATE - PER DAY	UP TO 3,888 US GPD (14,717 LPD)
MOTOR	3/8 HP, 14 AMPS
POWER SUPPLY	24VOLT DC, 385 WATTS PANEL, 9.6 AMP
MAXIMUM LIFT	175 FEET (53 METERS) OF WATER AT 76 PSI
DISCHARGE PER STROKE	0.06 GALLONS (0.22 LITERS)
TEMPERATURE RANGE	UP TO 200° F / 93° C

FIGURE 5: Performance Data - 102 Downhole

MAXIMUM EXTERNAL DIAMETER	2.9 INCHES (7.37 CENTIMETERS)
CONNECTION TO RISER PIPE	1-1/4 INCHES (3.18 CENTIMETERS)
CONNECTION TUBING	3/4 INCHES (1.9 CENTIMETERS) OR GREATER
RECOMMENDED INTERNAL BORE-HOLE DIAMETER	3 - 4 INCHES (7.62 - 10.16 CM) OR GREATER
DISCHARGE SIZE	2 INCHES OR 1-1/4 INCHES NPT
INSTALLATION	ANY ANGLE FROM VERTICAL TO HORIZONTAL
DRIVER WEIGHT	60 POUNDS (27.22 KILOGRAMS)
DRIVER ROD WEIGHT	12 LBS PER 100 FT (3.7 KG PER 100 M)
FOOT VALVE ASSEMBLY WEIGHT	17 POUNDS (7.71 KILOGRAMS)
MINIMUM WELL CASING SIZE	3 INCHES (7.62 CENTIMETERS)
FOOT VALVE ASSEMBLY WEIGHT	20 POUNDS (9.1 KILOGRAMS)

FIGURE 6: Technical Data - 102 Downhole

Limited Warranty

Pumps (excluding seals) manufactured by Blackhawk Technology Company (Blackhawk) are warranted, to the original user only, to be free of defects in material and workmanship for one year from the date of invoice.

Terms and Conditions

Final delivery date will be determined at time of order. All prices are in U.S. dollars, F.O.B. Glen Ellyn, IL USA. A copy of Buyers Purchase Order is required at time of order. "Delivery time on all specials will be determined after receipt of order." Terms are Net 30 days. Total quoted price does not include freight charges. Freight will be prepaid and added to Blackhawk Technology's final invoice to buyer. A service charge of 1.5% per month will be applied to all past-due invoices. Pricing is valid for 30 days. Notwithstanding anything contained herein to the contrary, the parties agree that the terms and conditions set forth in the limited warranty of Blackhawk Technology Company shall supersede any of the terms and conditions otherwise set forth.

Blackhawk's liability under this warranty shall be limited to repairing or replacing at Blackhawk's option, without charge, F.O.B. Blackhawk's factory, any product that Blackhawk manufactures. Blackhawk will not be liable for any costs of removal, installation, transportation or any other changes that arise in connection with a warranty claim. Products that are sold but not manufactured by Blackhawk are subject to the warranty provided by manufacturer of said products and not by Blackhawk's warranty. Blackhawk will not be liable for damage or wear to said products by abnormal operating conditions, accident, abuse, misuse, unauthorized alteration or repair, or if the product was not installed in accordance with Blackhawk's printed installation and operating instructions.

To obtain service under this warranty, the defective product must be returned to Blackhawk together with proof of purchase and installation date, failure date, and supporting installation data. Unless otherwise provided, contact will be made to Blackhawk for instructions prior to return of defective product. Any defective product to be returned to Blackhawk must be sent freight prepaid; documentation supporting the warranty claim/or a return Material Authorization must be included if so instructed.

Blackhawk will not be liable for any incidental or consequential damages, losses, or expenses arising from installation, use, or any other causes. There are not expressed or implied warranties, including mechanical ability of fitness for a particular purpose, that extend beyond those warranties described or referred to above.

Some jurisdictions do not allow the exclusion or limitation of incidental or consequential damages, and some jurisdictions do allow limitations on how long implied warranties may last. Therefore, the above limitations or exclusions may not apply to you. This warranty gives you specific legal rights and you may also have other rights that vary from jurisdiction to jurisdiction.

In the event of perceived failure of a Blackhawk Technology Company product, please follow this warranty claim procedure:

1. Verify that the problem is due to the suspected product and not another part of the system. You may call Blackhawk technical support for advanced troubleshooting assistance.
2. If you confirm that a Blackhawk product is defective, detail in writing the exact nature of the failure.
3. The product must be accompanied by notation of a dated proof of purchase, installation date, failure date and supporting installation data that are satisfactory to Blackhawk.
4. Return the product, the written description of the failure, and supporting notation to Blackhawk's home office, 1097 Hill Avenue, Glen Ellyn IL 60137, along with your address and a daytime phone number. Purchaser must prepay all delivery costs or shipping charges, as well as any other charges encountered in shipping any defective Blackhawk product under this warranty policy. No shipment will be accepted collect.
5. Any return from Blackhawk will be sent via Blackhawk's preferred shipping agent. Special shipping arrangements are available at the customer's expense.

