

V-2 Pneumatic Piston Pump™

PRODUCT OVERVIEW

- Flow range: To 11 US gpm; 41.6 lpm
- Operational depth: To 555 ft., 169 m.
- Any-size well casing

APPLICATIONS

- Landfill leachate and methane gas wells
- Elevated temperatures
- Chemically aggressive
- DNAPL/LNAPL
- Bio-reactive, crusty, foamy
- Deep, angled wells
- Harsh environments

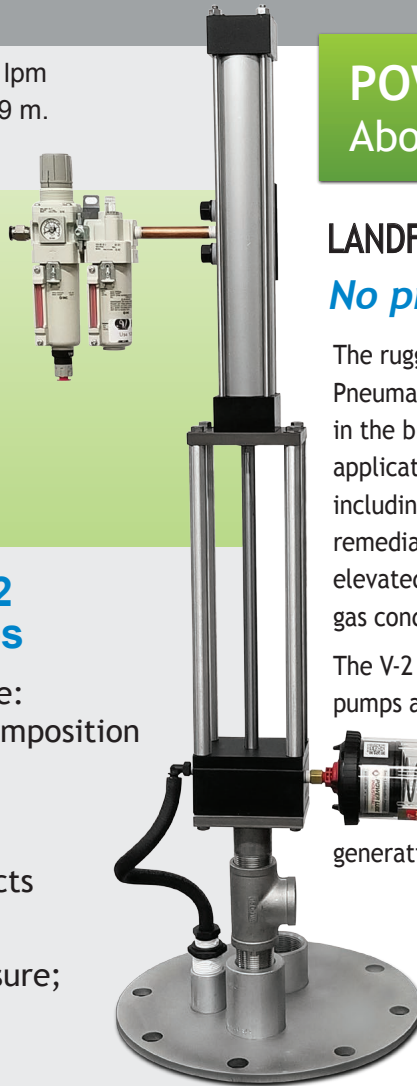

POWER & VERSATILITY

Above-Ground Motor

LANDFILLS, REMEDIATION, ELEVATED-TEMP WELLS

No pneumatic air in well or discharge

The rugged, dependable V-2 Pneumatic Piston Pump™ excels in the broadest range of pumping applications and environments, including NAPL recovery and remediation, landfill leachate, elevated-temperature to 350° F, gas condensate & dewatering.

The V-2 operates in winter and pumps any flowable liquid or semi-solid at any angle, a next-generation advantage over

electric submersibles and forced-air-push technologies.

By design, all pneumatic air enters and exits the pump driver above surface grade - no air is allowed in the well or sump. No oxygen contacts the fluid being discharged.

Models are available in three sizes to match flow, depth and air-consumption specifications. All can be customized with specialized materials of construction for site requirements.

10 Advantages of V-2 Over Air-Push Pumps

- 1 Pumps anything flowable: ET, viscous, unknown composition
- 2 Power and drive motor cleanly above wellhead
- 3 No pneumatic air contacts discharge, well fluids
- 4 Indifferent to well pressure; pumps dry
- 5 Less-frequent servicing, no pump pulling
- 6 Rugged, reliable materials adaptable to site needs
- 7 Operator-controlled rates avoid over-pumping
- 8 Operates at any angle to horizontal
- 9 Above-ground mechanicals safer for workers
- 10 Eco friendly; no hazardous gas forced into atmosphere

See how a piston pump works:
blackhawkco.com/how-blackhawk-solar-linear-rod-piston-pumps-work

Steady Flows to Submergence Depth

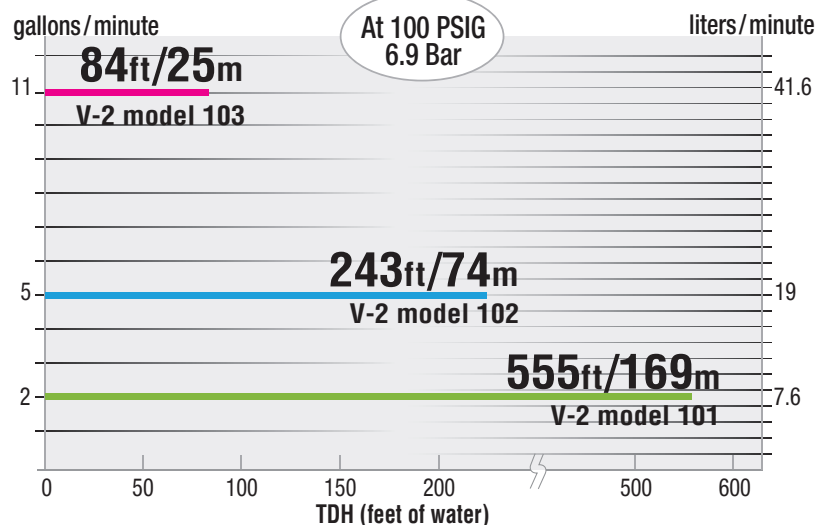

V-2 Pneumatic Piston Pump™

POWER & VERSATILITY Above-Ground Motor

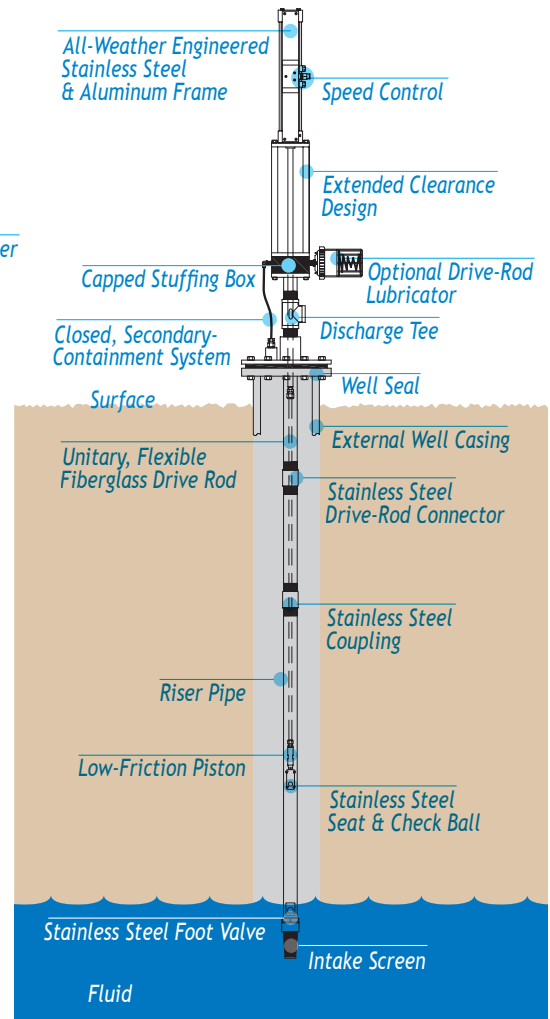
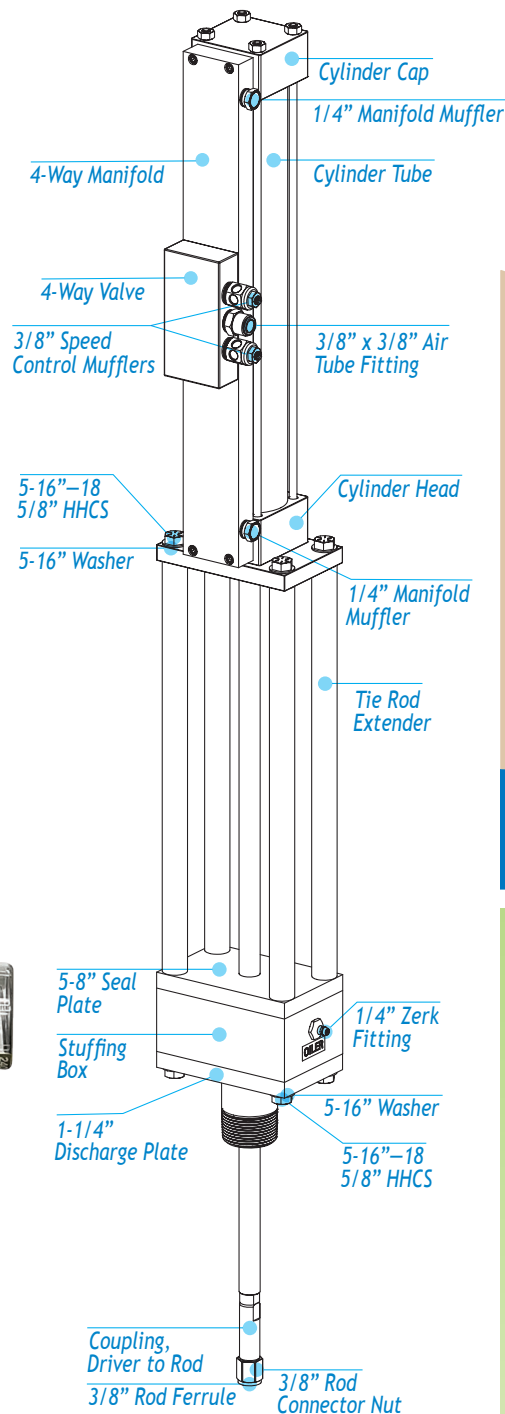
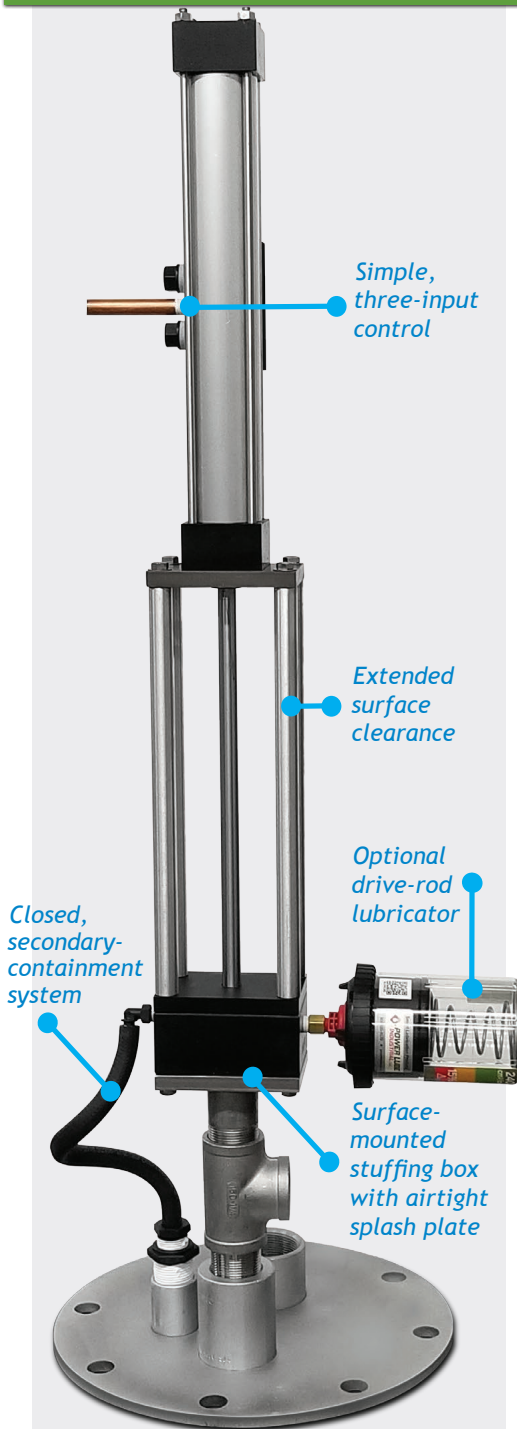

New Technologies in Fluid Management

Blackhawk is the originator and No. 1 manufacturer of above-wellhead, positive-displacement piston pumps - advanced technology refined by more than 25 years of customer-driven improvements.

Our low-flow reciprocating piston pumps are the standard for reliability and durability in landfills, remediation sites, elevated-temperature sites and other difficult pumping environments.

Visit www.blackhawkco.com to see why motors above the wellhead mean less-costly, more compliant, safer operations.

The best-performing environmental pump in the business

